

## INSTALLATION AND MAINTENANCE INSTRUCTIONS

### 3/4"- FILTERS

Thank you for selecting an Amiad filter. This filter has been designed to provide years of trouble free service. Please familiarize yourself with these instructions to ensure correct and reliable operation.

#### INSTALLATION

1. Amiad recommends using plastic connectors when installing the filter onto metal pipes.
2. Use only Teflon or silicon sealing material on the inlet/outlet connections. Do not use any sealing material on the plastic ball valve connection to the filter drain port. This is a compression type fitting and does not require any sealing material.
3. Install a shut-off valve before the filter to facilitate cleaning.
4. Install the filter oriented downward. Make sure to install according to the direction of water flow as shown.

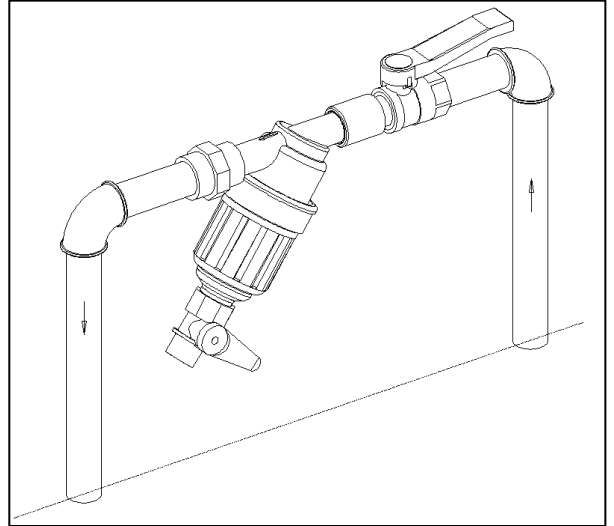

**WARNING:** Improper flow direction or backflow through a screen may damage the filter element.

#### CLEANING

The filter requires cleaning when pressure drop between the inlet and outlet reaches 0.5-0.6 bar (7-8 psi).

**WARNING: NEVER OPEN THE FILTER WHILE UNDER PRESSURE!**

1. Close the water supply to the filter and release pressure from the system.
2. Unscrew the filter bowl to remove the screen element.
3. Rinse the screen with water. Use a soft brush for hard-to-remove particles. Do not use a metal brush which may damage the screen.
4. Insert the filter element into the housing. Make sure that the housing and element seals are in place. Screw on the bowl until tight, then back-off 1/8 turn for proper sealing.
5. Close the drain valve and open the inlet valve to pressurize the filter. Check and correct any leaks.

**Maximum pressure drop across the filter element, for a short time should not exceed 6 bar (90 psi).**

**PARTS SCHEDULE: 3/4" FILTERS**

<b>3/4" FILTER, ACETAL (AC), W/O VALVE</b>		
<b>NO.</b>	<b>DESCRIPTION</b>	<b>CAT. NO.</b>
1	Housing 3/4" (AC, Black)	700190-001159
1.1	O-Ring P2-136	770102-000099
2	Bowl - closed (AC, Black)	710101-000449
5	MOLDED NYLON 110SQ.CM SCR. 130MIC F/3/4"AC	700101-000276
	As above, 22 micron	700101-000273
5	WEAVEWIRE ST316 110SQ.CM SCR.130MIC F/3/4"AC	700101-000300
	As above, 50 / 80 micron	700101-000297/8
5.1	O-Ring 34 x 2.3	770101-000038

<b>3/4" FILTER, ACETAL (AC), WITH VALVE</b>		
<b>NO.</b>	<b>DESCRIPTION</b>	<b>CAT. NO.</b>
1	Housing 3/4" (AC, Black)	700190-001159
1.1	O-Ring P2-136	770102-000099
2	Bowl - open (AC, Black)	710101-000447
5	MOLDED NYLON 110SQ.CM SCR. 130MIC F/3/4"AC	700101-000276
	As above, 22 micron	700101-000273
5	WEAVEWIRE ST316 110SQ.CM SCR.130MIC F/3/4"AC	700101-000300
	As above, 50 / 80 micron	700101-000297/8
5.1	O-Ring 34 x 2.3	770101-000038
7	Ball valve 3/4"	300005-000001

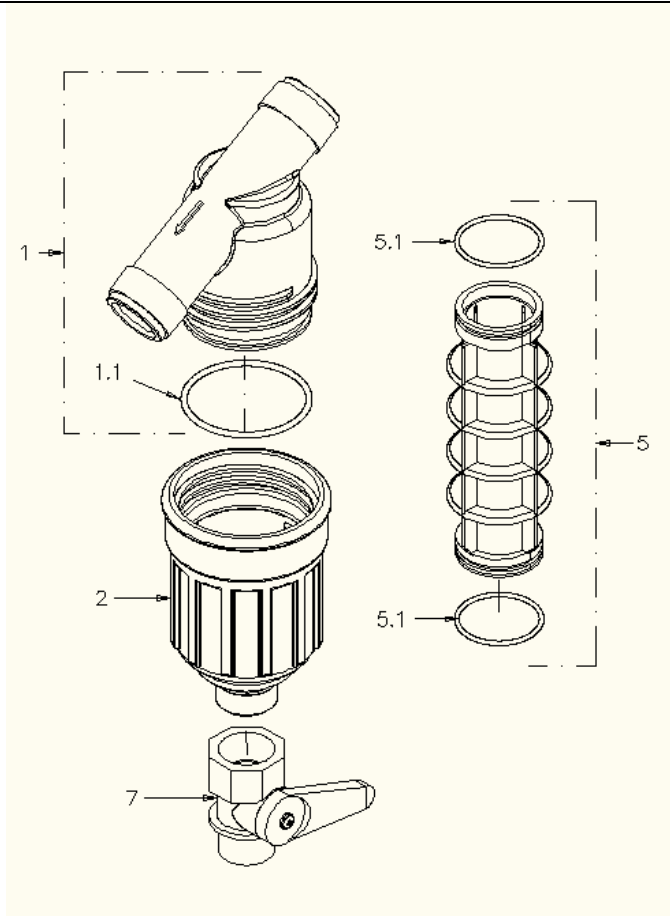

## AMIAD LIMITED WARRANTY

This certificate applies to Amiad Products purchased by You from Amiad or an Amiad authorized Distributor (“Distributor”). This limited warranty extends only to the original purchaser, and is not transferable to anyone who subsequently purchases, leases, or otherwise obtains the Product from the original purchaser.

1. Amiad hereby warrants that the Products are and will be free from defects in material and workmanship under normal use and service. Amiad warrants that it will correct manufacturing defects in the Products, in accordance with the conditions set out in this warranty.
2. This warranty is enforceable for a period of 12 months after the date Bill of Lading or equivalent (the “Warranty Period”).
3. In the event that during the Warranty Period the Distributor discovers a defect in material and/or workmanship in any Product or part (the “Defective Product”), it shall submit a written complaint to Amiad using Amiad's standard customer complaint form. For the receipt of the customer complaint form, the submission of the complaint or any questions please contact your customer service representative.
4. Upon written demand by Amiad the Distributor shall return the Defective Products – or a sample thereof – to Amiad, at Amiad's cost. If the customer ships any such Product, Amiad suggests the customer package it securely and insure it for value, as Amiad assumes no liability for any loss or damage occurring during shipment. Provided however that in the event Amiad determines that the warranty does not apply to such Product, Distributor shall promptly reimburse Amiad for such cost (including freight and customs). Any returned Product or part must be accompanied by the warranty certificate and the purchase invoice. It is clarified that the Distributor may not return the Defective Product unless such return was coordinate and approved by Amiad in advance.
5. Amiad's obligation under this warranty shall be limited to, at its option, the repair or exchange, free of charge, of the Product or any part which may prove defective under normal use and service during the Warranty Period. The provision of a repaired or replacement Product during the Warranty Period will result in an extension of the Warranty Period by an additional period of 12 months, provided that the total accumulated Warranty Period shall in any event be no more than 18 months from the original Bill of Lading.
6. This warranty is valid on the condition that the Products are installed according to Amiad's instructions as expressed in Amiad's instruction manuals and according to the technical limitations as stipulated in Amiad's literature or as stated by a representative of Amiad.
7. This warranty will not apply to damaged or defective Products resulting from or related to:
  - (i) Fire, flood, power surges or failures or any other catastrophe/and or unforeseen occurrence, such as but not limited to those for which the customers are customarily insured;
  - (ii) Fault, abuse or negligence of the customer;
  - (iii) Customer's responsibilities, including the failure of the intake water to meet the agreed standards, as set forth in a written document, approved by Amiad or improper storage.
  - (iv) Improper or unauthorized use of the Product or related parts by the customer, including the customer's failure to operate the Product in conformity with the recommendations and instructions of Amiad, as set forth in Amiad's manuals and other written materials, the operation of the Product other than by a trained and qualified operator, or improper installation of the Product by a third party not authorized by Amiad;
  - (v) Performance by the customer of maintenance and other services other than by a trained and qualified advanced operator, or other than in conformity with the recommendations and instructions of Amiad, or other than in accordance with procedures defined in the literature supplied for Products;
  - (vi) Any alteration, modification foreign attachment to or repair of the Products, other than by Amiad or its authorized technical representatives.
8. In no event shall Amiad be liable to the customer or any third party for any damages, including indirect, special, exemplary, punitive or consequential damages, or lost profits arising out of or in connection with this warranty, or arising out of or in connection with the Product's performance or failure to perform, even if it has been advised of the possibility of such damages.
9. Amiad will be excused for failure to perform or for delay in performance hereunder if such failure or delay is due to causes beyond its reasonable control or force majeure preventing or hindering performance.
10. The limited warranty set forth herein is the only warranty given by Amiad and is provided in lieu of any other warranties created by any documentation, packaging or otherwise.
11. Amiad makes no warranty whatsoever in respect of accessories or parts not supplied by Amiad. In the event that Amiad is required to correct a defective Product or product not covered by this warranty, it will do so solely in consideration for additional fees.